

Abstract

This work provides a study about the simulation of a medium voltage DC grid in an offshore wind farm [1]. The behavior in steady-state and during fault conditions is investigated. The efficiency of the network is determined in full-load conditions. Furthermore, key design aspects of such a grid are illustrated and issues regarding ripple current and converter design are treated.

Objectives

- Steady-state simulation of an offshore wind farm with a 30 kV MVDC grid connected with a HVDC model to an AC grid
- Highlight operational characteristics of a MVDC grid
- Show the voltage/current behavior during fault conditions
- Calculate the efficiency

OFFSHORE MVDC GRID OVERVIEW

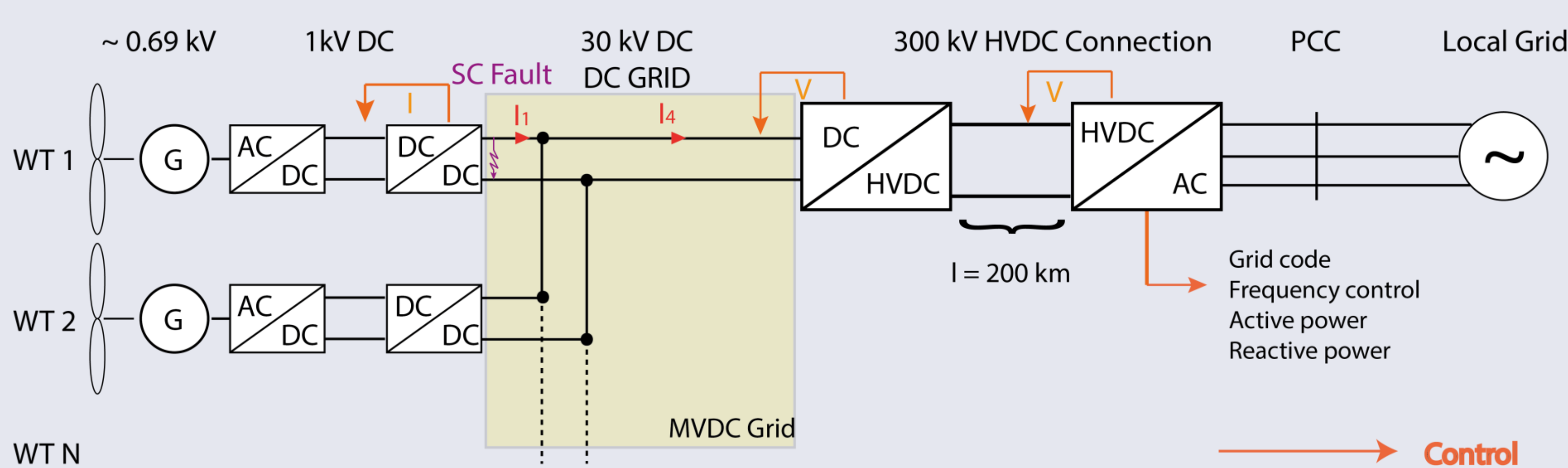

Schematic of an offshore DC grid with parallel bus design, HVDC link, grid representation and control strategies responsibilities.

Methods

- Representation of components with electrical models
- Focus on DC/DC converter structure and control
- Implementation in EMTDC PSCAD, 4 Wind Turbines

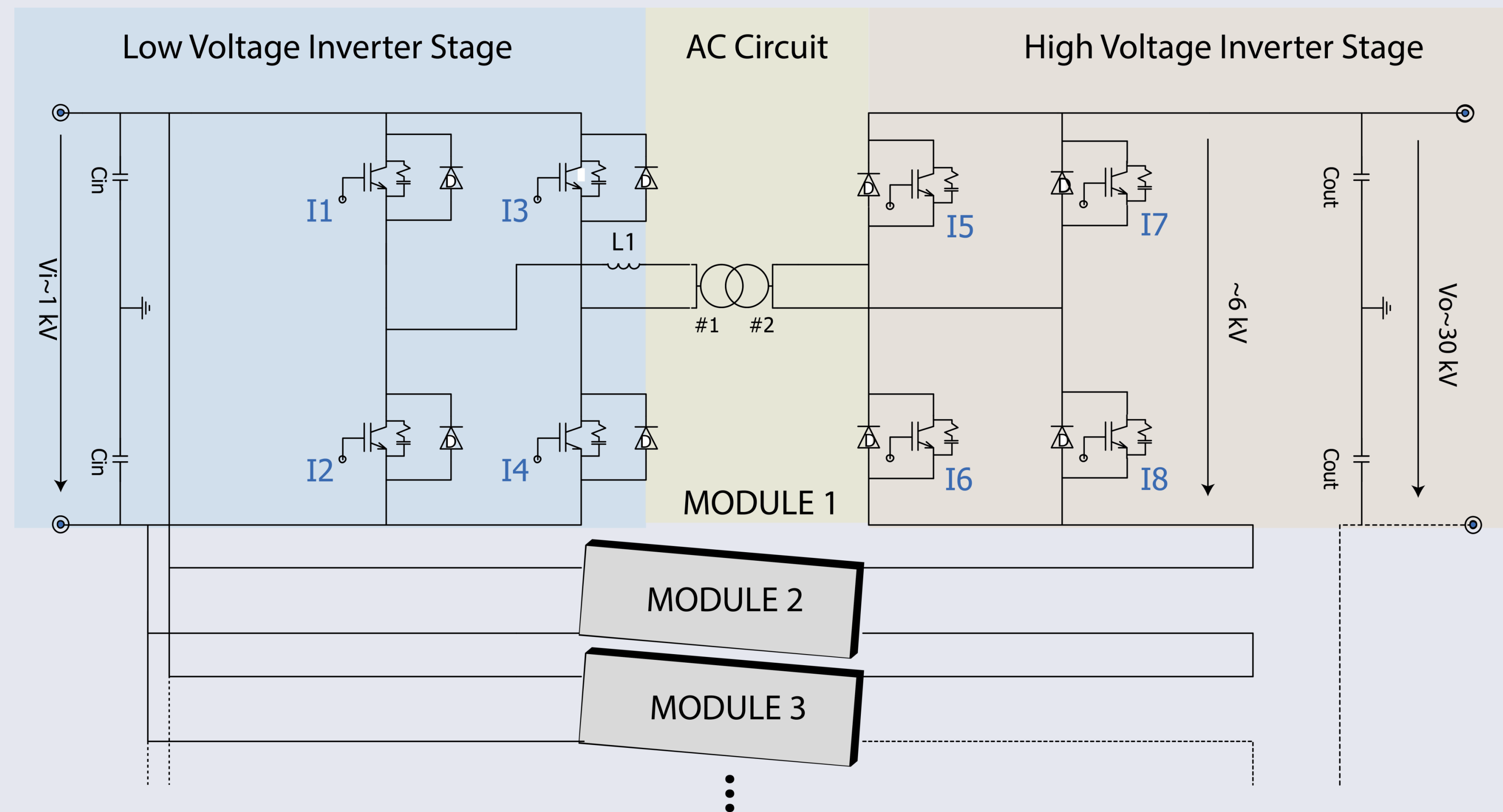

Dual active bridge (DAB) DC/DC Converter design controlled by dual phase shift (DPS) [2] control mode. Modular structure of converter to decrease conduction losses, improved transformer efficiency and voltage sharing on medium voltage stage. High input and output ripple current needs to be taken into consideration [3].

Additional Components

Type/Model

Control

Generator	Synchronous Gen.	Torque Control
AC/DC Low Voltage Conv.	Diode Bridge Rectifier	Passive
DC/HVDC High Voltage Conv.	Boost Converter	Voltage regulator
HVDC/AC High Voltage Conv.	Two-level-Full bridge IGBT DQ0 - PWM	
MVDC Cable Model	PI-Equivalent	None
HVDC Cable Model	Frequency Depended Phase Model	None

References

- [1] Meyer, C.; Hoing, M.; Peterson, A.; De Doncker, R.W., "Control and Design of DC-Grids for Offshore Wind Farms," *Industry Applications Conference, 2006. 41st IAS Annual Meeting. Conference Record of the 2006 IEEE*, vol.3, no., pp.1148,1154, 8-12 Oct. 2006
- [2] Bai, H.; Mi, C., "Correction to "Eliminate Reactive Power and Increase System Efficiency of Isolated Bidirectional Dual-Active-Bridge DC-DC Converters Using Novel Dual-Phase-Shift Control" (Nov 08 2905-2914)," *Power Electronics, IEEE Transactions on*, vol.27, no.9,
- [3] De Doncker, R.W.A.A.; Divan, D.M.; Kheraluwala, M.H., "A three-phase soft-switched high-power-density DC/DC converter for high-power applications," *Industry Applications, IEEE Transactions on*, vol.27, no.1, pp.63,73, Jan/Feb 1991
- [4] Meyer, C.; Kowal, M.; De Doncker, R.W., "Circuit breaker concepts for future high-power DC-applications," *Industry Applications Conference, 2005. Fourth IAS Annual Meeting. Conference Record of the 2005*, vol.2, no., pp.860,866 Vol. 2, 2-6 Oct. 2005

Results

Voltage stable but distorted current output in MVDC grid due to a lack of inductive components such as 50 Hz transformers!

Current flow - 30kV DC Grid - Current I1 and I4

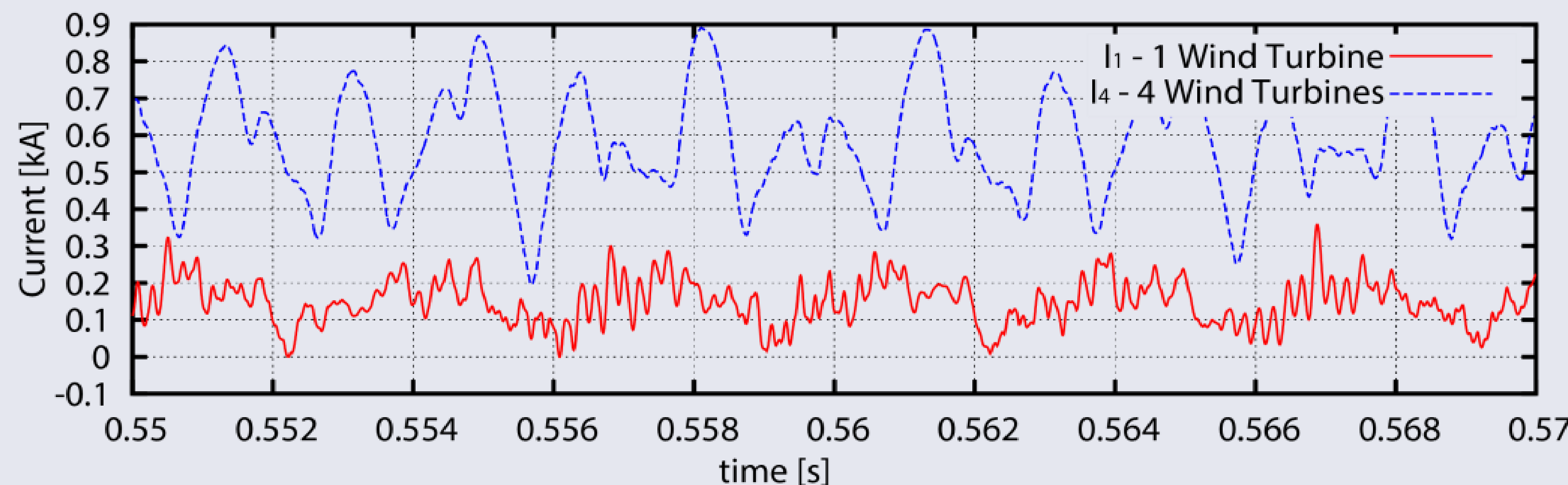

Current ripple in two different positions in the grid without damping measures.

How to reduce the ripple current?

1. Adding Inductance

Current flow- 10mH per pole added in Turbine and HVDC Boost Converter

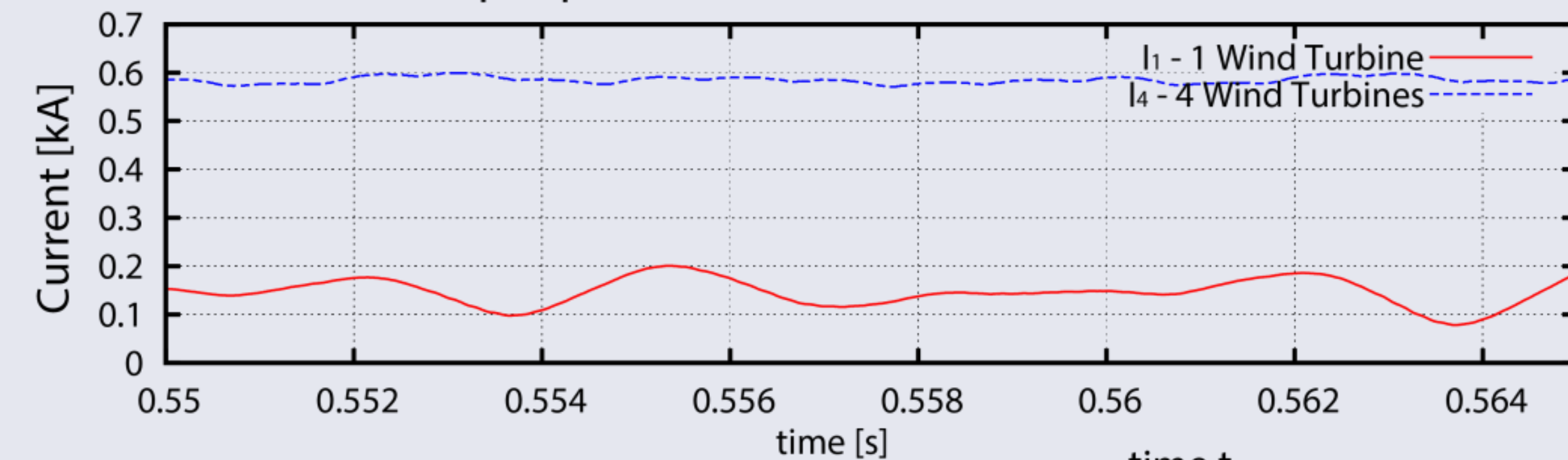

2. Control strategy for DAB converter

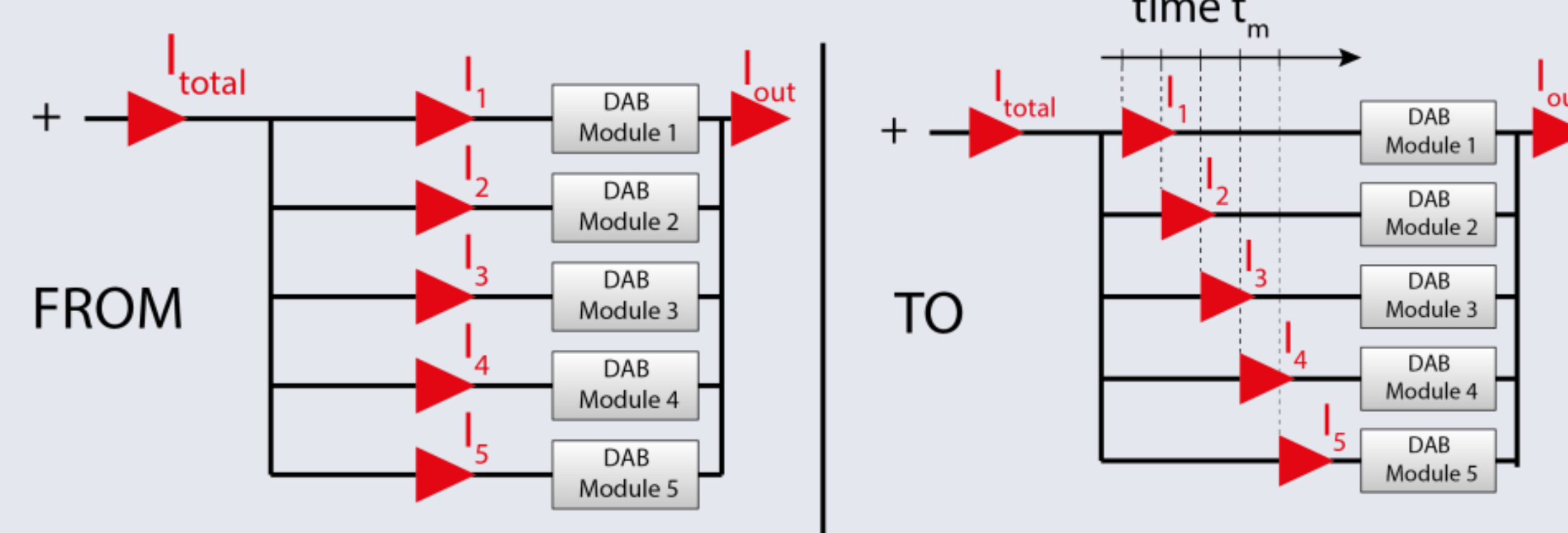

3. Different Converter Design

Fault analysis with reduced ripple current – SC in WT1

Wind Turbine Converter Fault-Bus Voltage and Fault Currents-WT Terminal 1

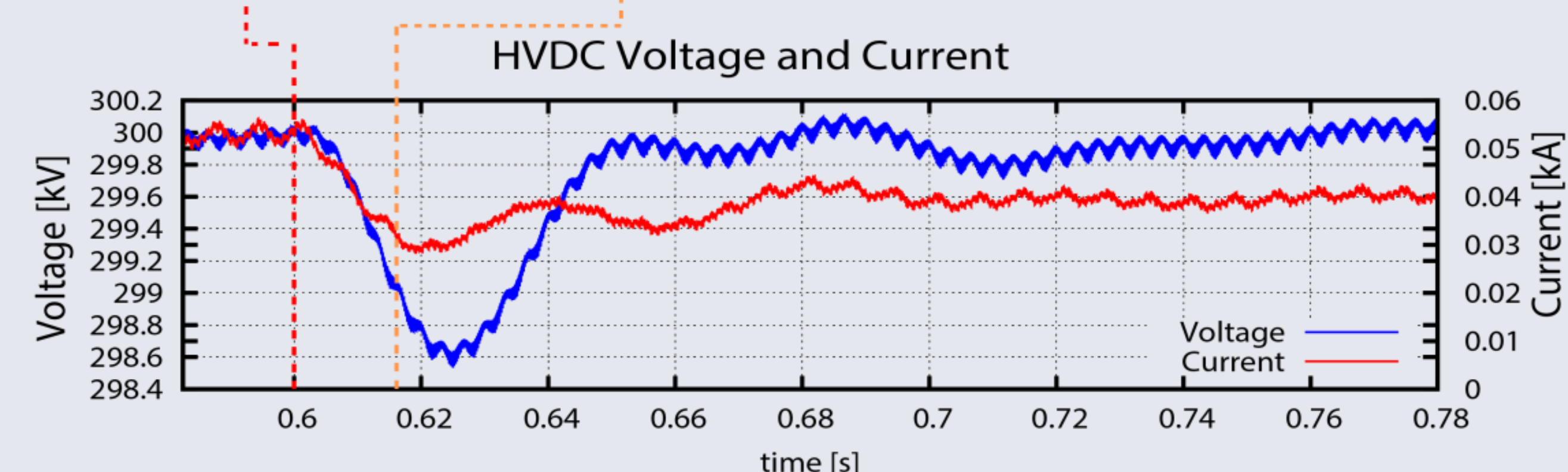
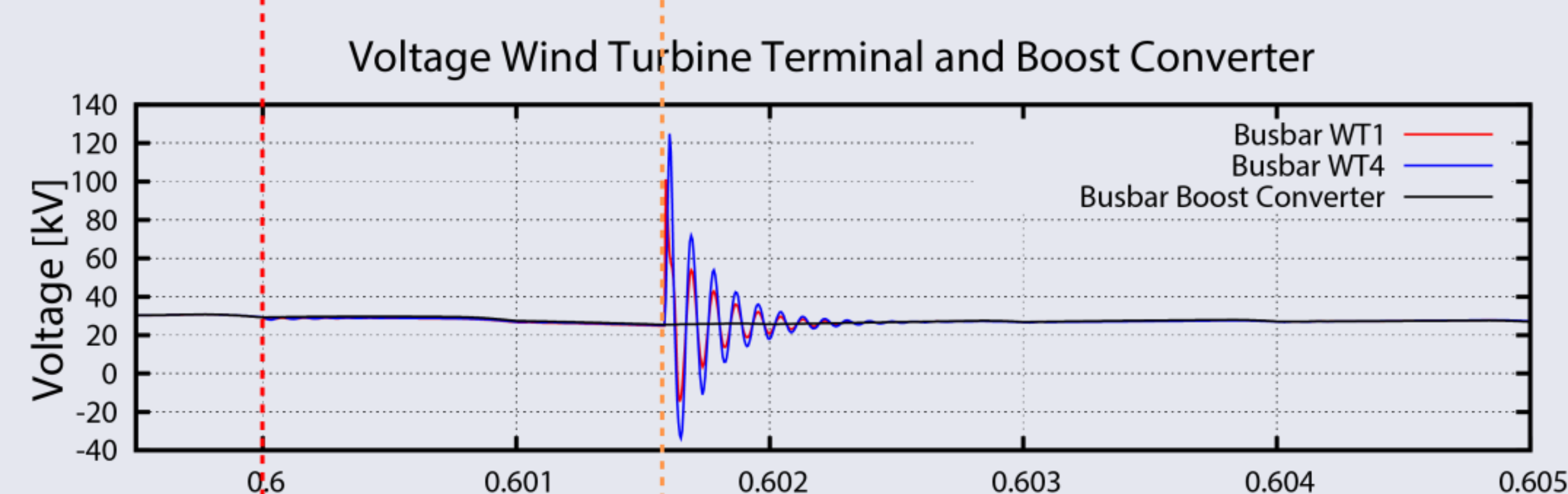
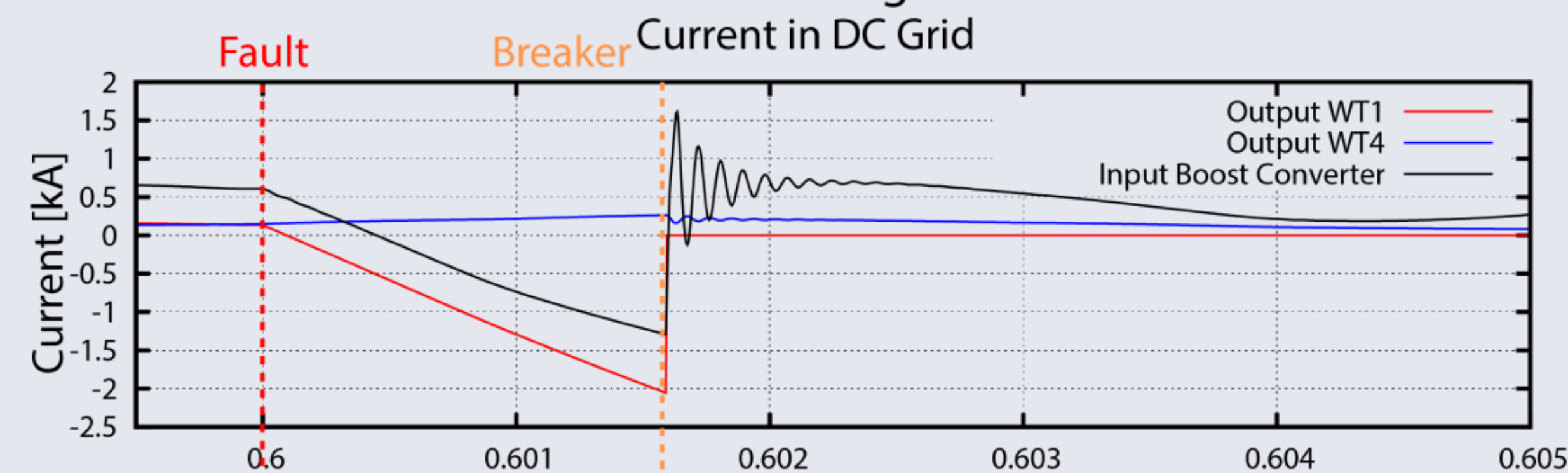

- Stable recovery after exclusion of the faulted turbine from the grid
- Short transient over voltages up to 4x U_{DC}
- Control system is able to handle the distortion
- Fault currents reached 3x I_{bc}
- High di/dt during fault currents only limited by cable inductances and breaker time

Short circuit in wind turbine, location of fault indicated in grid overview.

Conclusions

- DAB DC/DC Converter with high nominal input and output current ripple
- The MVDC grid needs to be stabilized with additional inductances and/or control strategies
- Due to low inductance, very fast DC breakers (t_{br}=1...1.5ms) [4] are essential to limit short circuit currents
- Grid efficiency is found to be 94.4% (Calculation includes conduction and switching loss of: diode rectifier, DAB converter, MVDC cables)

